



## APPLICATION: Drinking Water Filtration

The 3M™ Drinking Water System provides cleaner, better tasting water by reducing common contaminants. It fits easily under your kitchen sink and operates through a dedicated faucet (included).

This system helps address a number of contaminants that may be found in your water including chlorine taste and odor, sediment, lead, mercury, asbestos, cysts and others (please refer to Performance Data Sheet). System is certified for 0.75 gallons per minute of filtered water. The replacement filter is easy to change – twist on, twist off, no mess.



**MODEL: 3MDW101**

### PRODUCT BENEFITS:

- Reduces chlorine taste and odor, sediment, lead, mercury, asbestos and cysts to help provide better tasting water and cleaner ice cubes.
- Designed with built-in bypass valve – no need to shut off water for filter change.
- Easy to maintain, filter change is a twist.
- Small compact design that easily fits under your sink.
- Ease of installation when using existing sprayer or soap dispensing hole in sink.

### PRODUCT SPECIFICATIONS:

Model/Part Number	Reduction Claims	Dimensions (Ht. x Dia.)	Approx. Weight	Service Flow Rate	Temperature Range	Pressure Range	Capacity	Replacement Filter
3MDW101	Chlorine Taste and Odor, Sediment, Lead, Mercury, Asbestos & Cysts*	12.5" x 2.9" (31.8 cm x 7.5 cm)	2.4 lbs (1.1 kg)	0.75 gpm (2.8 lpm)	40 - 100°F (4.4 - 37.8°C)	25 - 120 psi (172 - 827 kPa)	500 gallons (1,893 liters)	3MDW111

\* See Performance Data Sheet for details and additional reduction claims

To obtain additional information please call our Customer Care team at 855-3M-WATER or visit our website at [www.3MWater.com](http://www.3MWater.com)

## INSTALLATION DIFFICULTY



Skills Needed: (Please refer to installation difficulty chart on website for additional information)

- Novice plumbing skills required if hole in sink is already present for dedicated faucet
- Professional installation recommended if no hole in sink is present for dedicated faucet

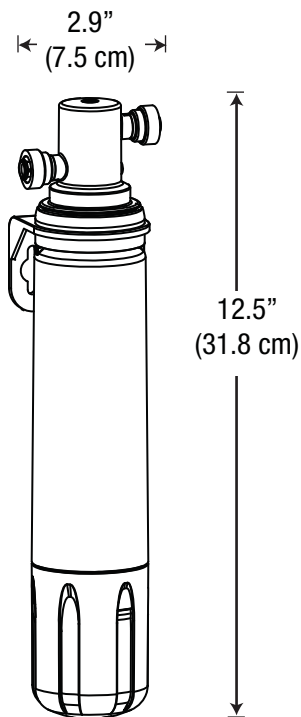

## SPECIFICATIONS

- 1/4" Quick Connect fittings.
- System is a single vessel design.
- System is NSF Standards 42 and 53 certified.
- System has a maximum operating pressure of 120 psi (827 kPa) and operating temperature of 100°F (37.8°C).
- System includes attached mounting bracket, filter and faucet.
- System to be installed on primary kitchen or bath cold water line.

## IMPORTANT

**⚠ WARNING: To reduce the risk associated with the ingestion of contaminants:**

- **Do not use with water that is microbiologically unsafe or of unknown quality without adequate disinfection before or after the system.** Systems certified for cyst reduction may be used on disinfected water that may contain filterable cysts.

EPA Establishment # 070595-CT-001

**CAUTION: To reduce the risk associated with property damage due to water leakage:**

- **Read and follow** Use Instructions before installation and use of this system.
- Installation and use **MUST** comply with all state and local plumbing codes.
- **Do not install** if water pressure exceeds 120 psi (827 kPa). If your water pressure exceeds 80 psi (552 kPa), you must install a pressure limiting valve. Contact a plumbing professional if you are uncertain how to check your water pressure.
- The disposable replacement filter **MUST** be replaced every 6 months, at the rated capacity or sooner if a noticeable reduction in flow rate occurs.

3M Purification Inc. recommends regularly scheduled maintenance and replacement of the filters in order for the product to perform as advertised. 3M Purification Inc. shall not be liable for system failures due to improper maintenance.

## LIMITED WARRANTY

3M Purification Inc. warrants this Product will be free from defects in material and manufacture for the following periods from the date of purchase. Twelve (12) year for the Product, except for the replacement filter cartridge, which is warranted for one (1) year. This warranty does not cover failures resulting from abuse, misuse, alteration or damage not caused by 3M Purification Inc. or failure to follow installation and use instructions. No warranty is given as to the service life of any filter cartridge or membrane as it will vary with local water conditions and water consumption. **3M PURIFICATION INC. MAKES NO OTHER WARRANTIES OR CONDITIONS, EXPRESS OR IMPLIED, INCLUDING, BUT NOT LIMITED TO, ANY IMPLIED WARRANTY OR CONDITION OF MERCHANTABILITY OR FITNESS FOR A PARTICULAR PURPOSE OR ANY IMPLIED WARRANTY OR CONDITION ARISING OUT OF A COURSE OF DEALING, CUSTOMER OR USAGE OF TRADE.** If the Product fails to satisfy this Limited Warranty during the warranty period, 3M Purification Inc. will replace the Product or refund your Product purchase price. This warranty does not cover labor. **The remedy stated in this paragraph is Customer's sole remedy and 3M Purification Inc.'s exclusive obligation. For additional information, see the entire Limited Warranty located in the product Installation and Operating Instruction Manual.**

**Limitation of Liability.** 3M Purification Inc. will not be liable for any loss or damage arising from this 3M Purification Inc. product, whether direct, indirect, special, incidental, or consequential, regardless of the legal theory asserted, including warranty, contract, negligence or strict liability. Some states and countries do not allow the exclusion or limitation of incidental or consequential damages, so the above limitation or exclusion may not apply to you.



3M Purification Inc.  
400 Research Parkway  
Meriden, CT 06450

855-3M-WATER (855-369-2837)  
www.3MWater.com